



EPL185

Electric Pallet Truck 1.8T

- Reliable drive system ;
- Fast charging;
- Convenient to use;
- Easy maintenance and more durable.

EP EQUIPMENT CO.,LTD
www.ep-ep.com

FEATURE

■ Optimized structure, easy operation

The metal protective cover of battery can be flipped over, which can effectively protect the battery; The battery has simple cover with two combination modes, it can prevent the battery from plugging and unplugging at will.



■ Safe

The truck uses the second generation drive technology and brushless DC motor. There is no need to replace the carbon brush and the drive is more powerful. Its max. Gradeability can reach 10% for the high power version.



■ New plug-in&out battery design

On-board charger with plug-in&out battery to satisfy different working condition.

Fast charging can be optionally equipped with.

Li-ion battery developed by EP is equipped with CAN and BMS, which is more convenient to use.



■ Rigorous design and convenient maintenance

Floating battery cartridge to protect battery contact pins.

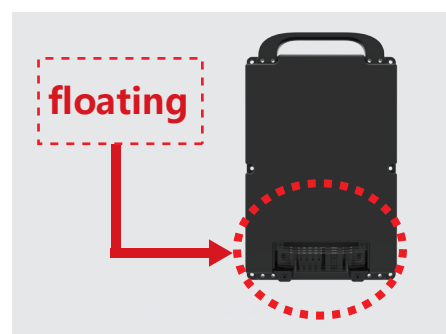

Electric Pallet Truck 1.8T

EPL185

Distinguishing mark				
1.1	Manufacturer			EP
1.2	Model designation			EPL185
1.3	Drive unit			Battery
1.4	Operator type			Pedestrian
1.5	rated capacity	Q	kg	1800
1.6	Load center distance	c	mm	600
1.8	Load distance	x	mm	940(875)
1.9	Wheelbase	y	mm	1200(1135)
Weight				
2.1	Service weight (include battery)		kg	160(170)
2.2	Axle loading, laden driving side/loading side		kg	660/1400
2.3	Axle loading, unladen driving side/loading side		kg	130/30
Types,Chassis				
3.1	Tyre type driving wheels/loading wheels			PU/PU
3.2	Tyre size, driving wheels (diameter×width)		mm	Φ210x70
3.3	Tyre size, loading wheels (diameter×width)		mm	Φ80x60(Φ74x88)
3.4	Tyre size, caster wheels (diameter×width)		mm	Φ74x30
3.5	Wheels, number driving, caster/loading (x=drive wheels)		mm	1x, 2/4(1x, 2/2)
3.6	Track width, front,driving side	b10	mm	450
3.7	Track width,rear,loading side	b11	mm	390/(535)
Dimensions				
4.4	Lift height	h3	mm	115
4.9	Height drawbar in driving position min./max.	h14	mm	700/1260
4.15	Lowered height	h13	mm	80
4.19	Overall length	l1	mm	1550
4.20	Length to face of forks	l2	mm	400
4.21	Overall width	b1/ b2	mm	610(695)
4.22	Fork dimensions	s/ e/ l	mm	50x150x1150
4.25	Distance between fork-arms	b5	mm	540(685)
4.32	Ground clearance, center of wheelbase	m2	mm	30
4.34.1	Aisle width for pallets 1000 × 1200 crossways	Ast	mm	2145
4.34.2	Aisle width for pallets 800 × 1200 lengthways	Ast	mm	2050
4.35	Turning radius	Wa	mm	1330
Performance data				
5.1	Travel speed, laden/ unladen	km/ h	km/h	5/5.5
5.2	Lifting speed, laden/ unladen		m/ s	0.020/0.025
5.3	Lowering speed, laden/ unladen		m/ s	0.065/0.030
5.8	Max. gradeability, laden/unladen		%	6\16
5.10	Service brake type			electric
Electric-engine				
6.1	Drive motor rating S2 60 min		kW	0.9
6.2	Lift motor rating at S3 15%		kW	0.8
6.3	The maximum allowed size battery		mm	270*110*440
6.4	Battery voltage/nominal capacity K5		V/ Ah	48/20 (30)
6.5	Battery weight		kg	14
Addition data				
8.1	Type of drive control			DC
10.5	Steering type			mechanical
10.7	Sound pressure level at the driver's ear		dB (A)	<74

If there are improvements of technical parameters or configurations, no further notice will be given.
The diagram shown may contain non-standard configurations.

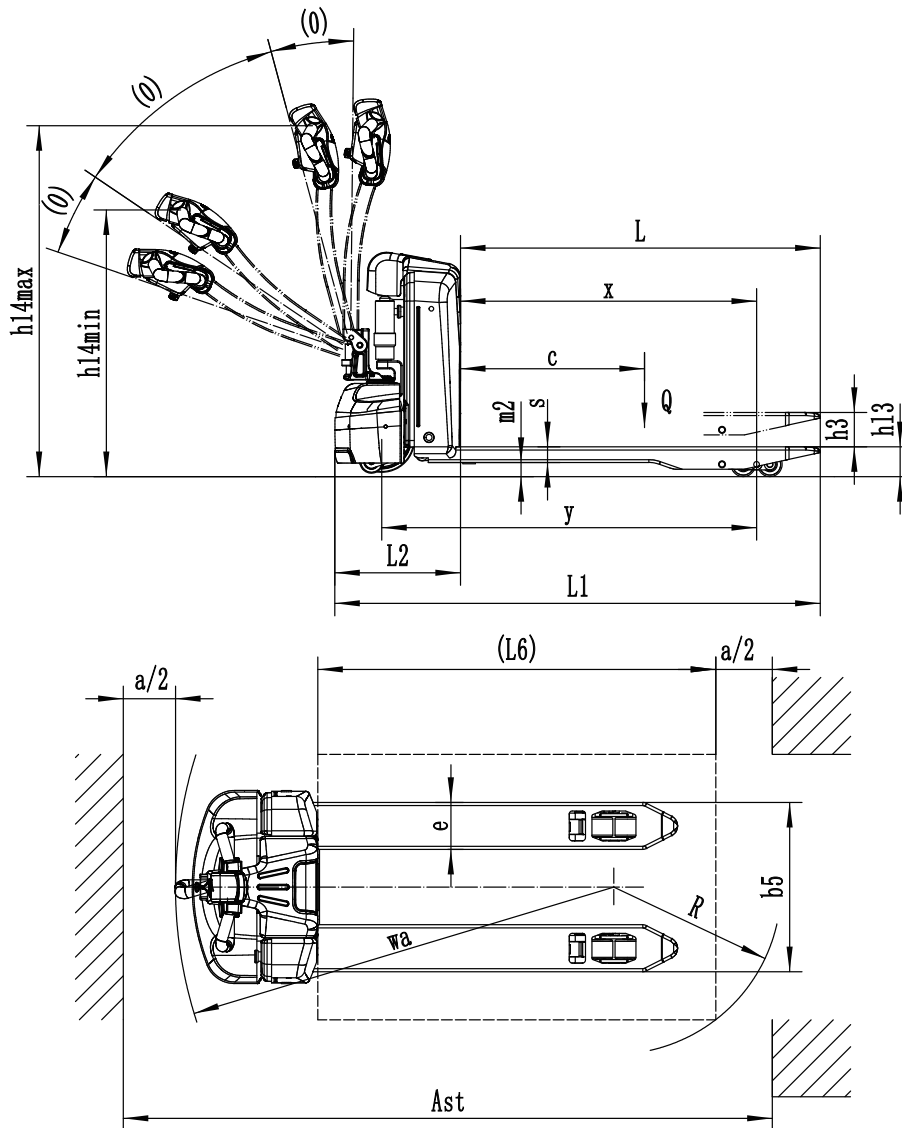

Option:

Optional items		EPL185
1	Fork length	1150/900/1000/1220/1350/1500
2	Fork width	○540/○685
8	Double load wheel	●
9	Single load wheel	○
10	Driving wheel	-
11	Balance wheel	●
15	cold storage	-
17	Battery indicator with hour meter	●
18	Battery indicator without hour meter	-
19	Battery capacity	48V/20Ah (30AH)
20	Lateral change battery	-
22	Water auto-filling system	-
25	Vertical handler working	●
31	half speed function in turning	-
32	Guard arm	-
33	Fork lowered height	-
34	Special backrest	-

Note: ● standard ○ option — NA