

eAA-9MC

ARTICULATED CRAWLER BOOM

OUR TRUE MISSION
ZERO EMISSIONS

MODEL HIGHLIGHTS

- Extended battery performance, AGM maintenance-free battery
- Hand pump emergency lowering system
- 360° continuous turntable rotation
- Reduced tail swing
- Low ground pressure
- Grey non-marking tracks
- Zero emission engine

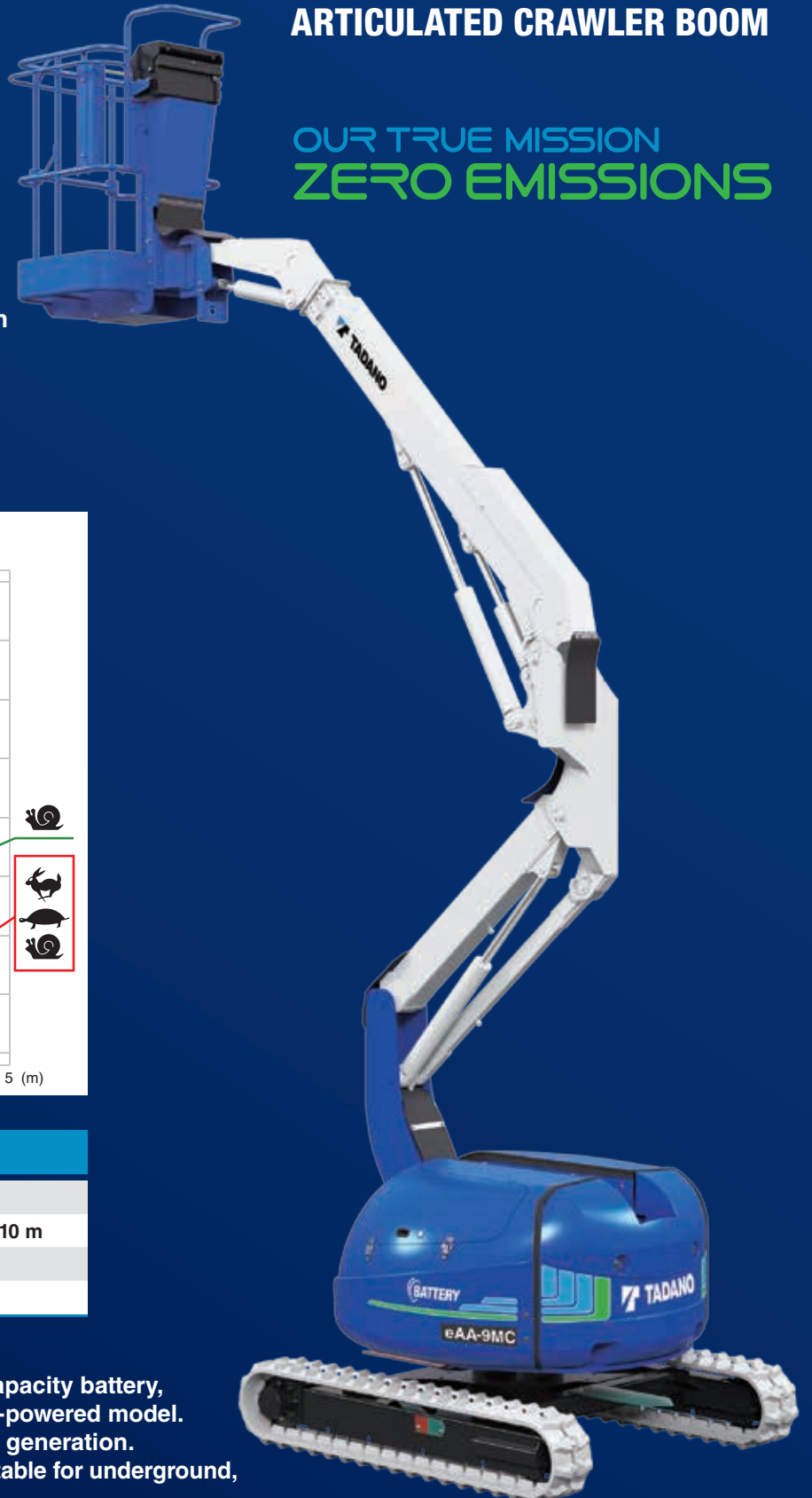

eAA-9MC Range of motion

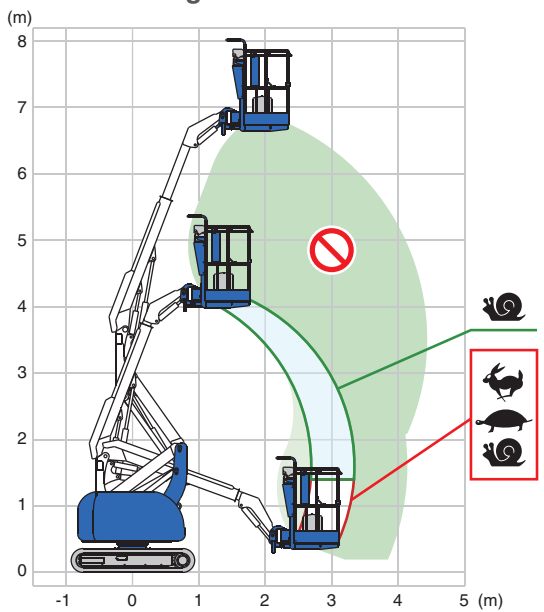

Model	eAA-9MC
Max. platform capacity	150 kg
Platform size	0,92 x 0,73 x 1,10 m
Max. work height	8,80 m
Max. outreach	4,50 m

Designed with AC motor and high-capacity battery, equivalent power and drive to diesel-powered model. Clean, quiet, low vibration, less heat generation. Ideal for urban construction; also suitable for underground, tunnel and indoor construction.

Model		eAA-9MC	
SPECIFICATIONS		POWER SOURCE	
Max. work height	8,80 m	Engine type	AC 3 phase
Max. outreach	4,50 m	Rated power	5 kW
Allowable tilt	5°	Capacity	260 Ah
Max. platform capacity	150 kg	System voltage	8 x 6 V
Platform size (L x W x H)	0,92 x 0,73 x 1,10 m	OPTIONS	
Platform rotation	L90° ~ R40°	LED lighting*	
Transport dims (L x W x H)	4,08 x 1,65 x 2,00 m	SAFETY DEVICES	
Machine weight	2.740 kg	Emergency stop	✓
AC outlet to platform (230 V)		Foot switch / Enabling switch	✓
TRAVEL		Auxiliary lowering control	✓
Max. travel speed	2,2 km/h	Traveling restriction (on slope)	✓
Max. ground pressure	75 kPa	Operation restriction (on slope)	✓
Travel position ground pressure	39 kPa	Battery isolator switch	✓
Max. gradeability	42 %		

* rear and upper control box only

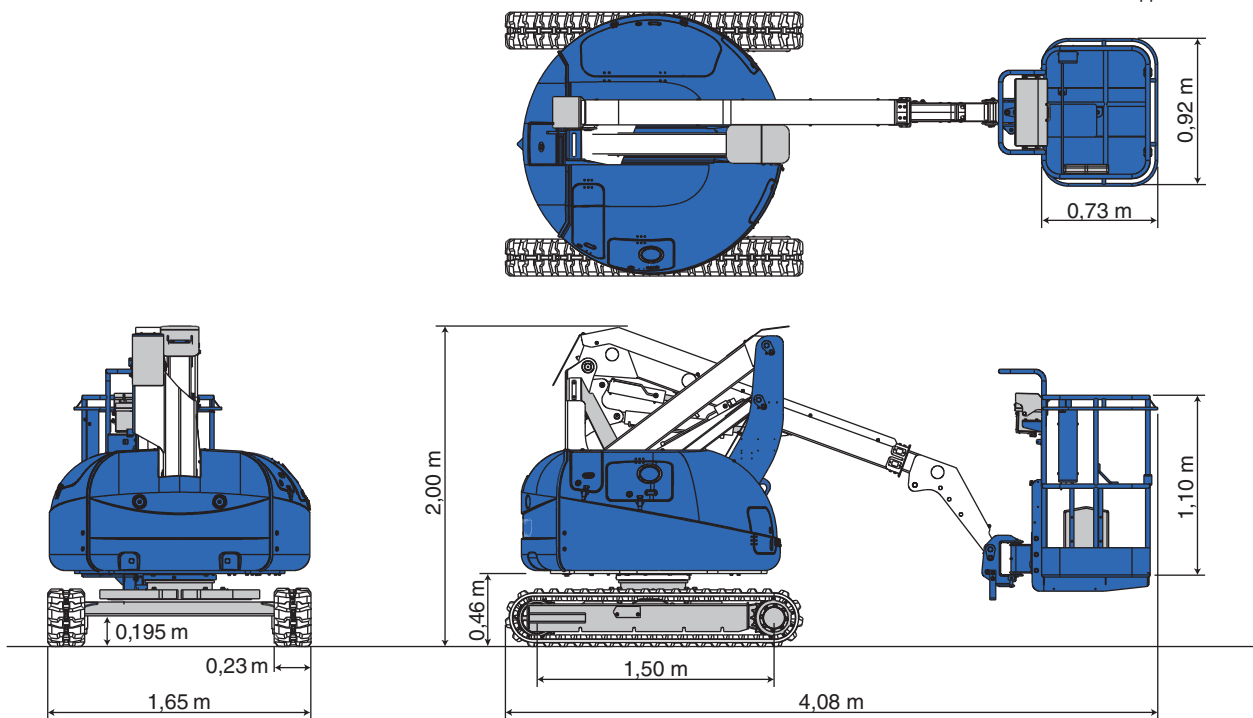

For all our types:



December 2025. Unless otherwise specified, all information in this brochure refers to a standard equipment, and it is intended as general information only. No liability is assumed. Errors reserved. Product specifications and prices are subject to changes without notice. The photographs and/or drawings in this brochure are for illustrative purposes only. For correct and safe operation, the original operating manual and lifting capacity charts are essential. Failure to follow the corresponding Operator's Manual when using our equipment or failure to otherwise act responsibly may result in property damage, serious injury or death. The sole warranty applicable with respect to our equipment is the standard warranty as per general terms and conditions of sales and service (ask your local Tadano dealer for details), and Tadano makes no other warranty, express or implied. All rights reserved. Any use of the trademarks, logos, brand names and model names used herein is prohibited.

© Tadano Ltd. 2025

Tadano Ltd.

Kanda Square 18th Floor, 2-2-1 Kanda-Nishikicho, Chiyoda-ku, Tokyo 101-0054, Japan
Phone: +81-3-6811-7309 (International Division)

info@tadano.com

www.tadano.com

Tadano Europe Holdings GmbH

Dinglerstr. 24, 66482 Zweibrücken, Germany, Phone: +49 (0) 6332 83-0

